

# Jupiter GPS Receiver

# NAVMAN

## TU30-D400 Series Data Sheet, Revision A

NAVMAN's Jupiter Global Positioning System (GPS) module is a single-board, 12 parallel-channel receiver intended as a component for an Original Equipment Manufacturer (OEM) product. The receiver continuously tracks all satellites in view and provides accurate satellite positioning data. Jupiter is designed for high performance and maximum flexibility in a wide range of OEM configurations including handhelds, panel mounts, sensors, and in-vehicle automotive products.

The highly integrated digital receiver uses the Zodiac chipset composed of two custom SIRF devices: the Gemini/Pisces MonoPac™ and the Scorpio Baseband Processor (BP). These two custom chips, together with memory devices and a minimum of external components, form a complete low-power, high-performance GPS receiver solution for OEMs. Configurations allow the OEM to design for multi-voltage operation, SIRF's Hardware Accelerator device (CX11239), or dead reckoning navigation that uses vehicle sensors in the absence of GPS signals. Each configuration provides up to three options for different types of antenna connectors (see Ordering Information at the end of this document).

The Jupiter receiver decodes and processes signals from all visible GPS satellites. These satellites, in various orbits around the Earth, broadcast radio frequency (RF) ranging codes, timing information, and navigation data messages. The receiver uses all available signals to produce a highly accurate navigation solution that can be used in a wide variety of end product applications. This solution is relatively immune to the position jumps induced by blockage that can occur in receivers with fewer channels.

The all-in-view tracking of the Jupiter receiver provides robust performance in applications that require high vehicle dynamics and in applications that operate in areas of high signal blockage such as dense urban areas.

The Jupiter receiver (shown in Figures 1 and 2) is packaged on a miniature printed circuit board with a metallic RF enclosure on one side. The receiver is available in four configurations. The configuration and type of antenna connector must be selected at the time of ordering and is not available for field retrofitting.

Part Number	Description
TU30-D400-xxx	+3.3 V operation, low power consumption
TU30-D410-xxx	+5.0 V operation, standard version
TU30-D420-xxx	+3.3 V operation with dead reckoning navigation
TU30-D430-xxx	+3.3 V operation with the CX11239
TU30-D440-xxx	+5.0 V operation with dead reckoning navigation
<b>Note 1:</b>	See Ordering Information on last page for numbering details

**Table 1. Jupiter GPS Receiver TU30-D400 Series Configurations**

## Features

- Uniform printed circuit board design for all four available configurations
- Twelve parallel satellite tracking channels for fast acquisition and reacquisition
- Fast Time-To-First-Fix (TTFF) performance if required or minimum power consumption for standard operation
- Less than 8 seconds TTFF hot start, less than 40 seconds cold start with the CX11239
- Less than 1 second reacquisition after blockages up to 10 seconds
- Enhanced algorithms provide superior navigation performance in "urban canyon" and foliage environments
- Adaptive threshold-based signal detection for improved reception of weak signals
- Maximum navigation accuracy achievable with the Standard Positioning Service (SPS)
- Automatic altitude hold mode from Three-Dimensional to Two-Dimensional navigation
- Automatic cold start acquisition process (when no initialization data is entered by the user)
- Maximum operational flexibility and configurability via user commands over the host serial port
- Ability to accept externally supplied initialization data over the host serial port
- User selectable satellites
- User selectable visible satellite mask angle
- Serial data output that includes NAVMAN binary protocol and selected National Marine Electronics Association (NMEA-0183) v2.1 messages

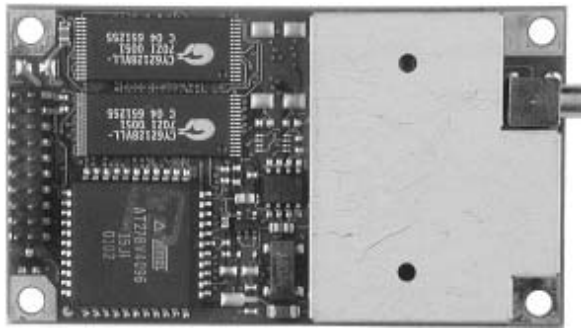

Figure 1. Jupiter GPS Receiver (Top view, shown approximately actual size)

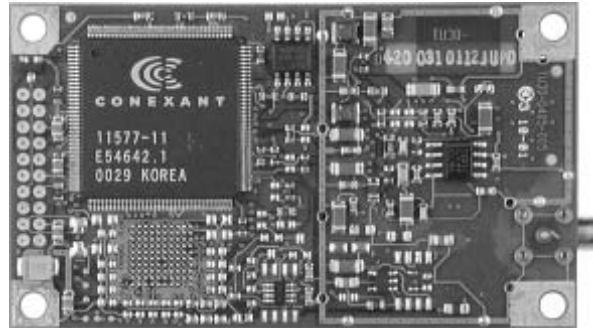

Figure 2. Jupiter GPS Receiver (Bottom view, shown approximately actual size)

The 12-channel architecture provides rapid TTFF under all startup conditions. While the best TTFF performance is achieved when time of day and current position estimates are provided to the receiver, the flexible signal acquisition system uses all available information to provide a rapid TTFF. Acquisition is guaranteed under all initialization conditions as long as visible satellites are not obscured. With the optional CX11239, TTFF can be reduced even further, sometimes by more than 75 percent.

The receiver supports Two-Dimensional operation when less than four satellites are available or when required by operating conditions. Altitude information required for Two-Dimensional operation is determined by the receiver or may be provided by the OEM application.

Communication with the receiver is established through one of two asynchronous serial I/O ports that support full duplex data communication. The receiver's serial port outputs navigation data and accepts commands from the

OEM application in proprietary NAVMAN binary message format. NMEA formatted message protocol is also available with software and/or hardware selection.

**Receiver Architecture.** The functional architecture of the basic Jupiter receiver is shown in Figure 3. Figure 4 shows the Jupiter with the CX11239 and Figure 5 shows the Jupiter with dead-reckoning circuitry. The receiver design is based on the SIRF Zodiac chipset: the Gemini/Pisces MonoPac™ and the Scorpio BP. The Gemini/Pisces MonoPac contains all the RF downconversion and amplification circuitry, and presents the In-Phase (I) and Quadrature-Phase (Q) Intermediate Frequency (IF) sampled data to the BP. The BP contains an integral microprocessor and the required GPS-specific signal processing hardware. Memory and other external supporting components configure the receiver into a complete navigation system.

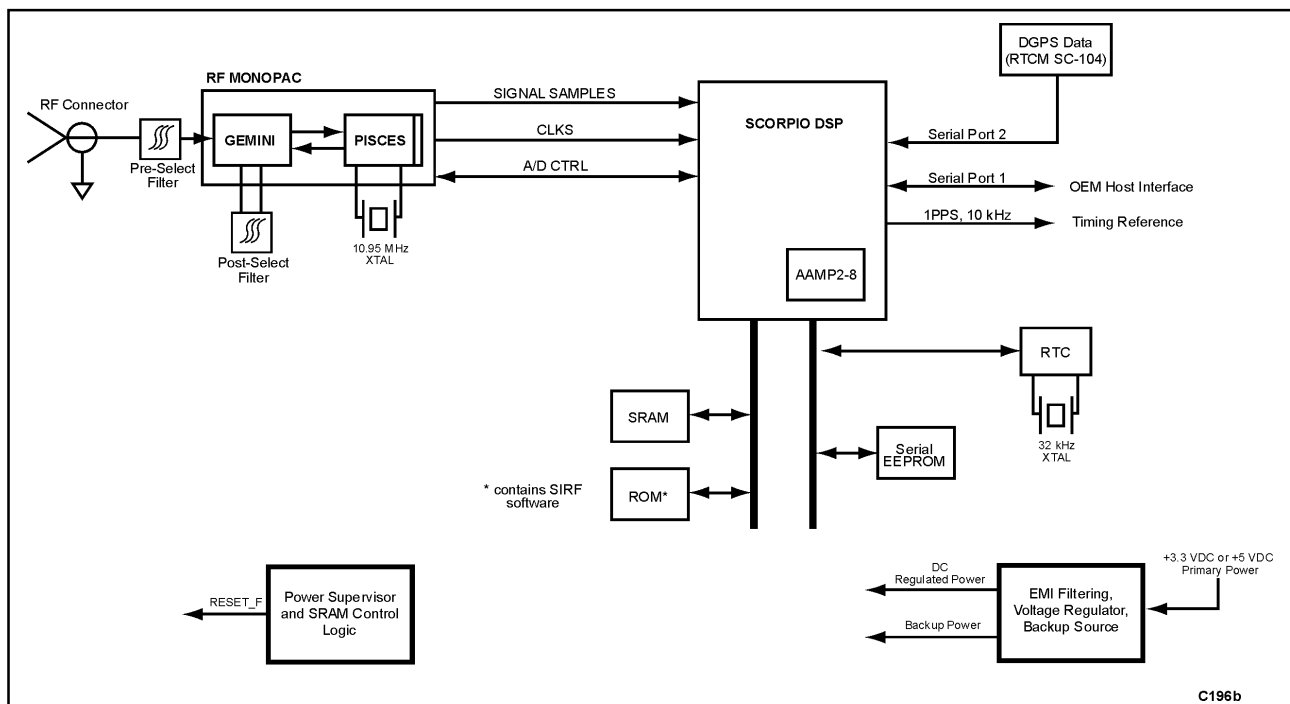

Figure 3. Basic Jupiter Block Diagram

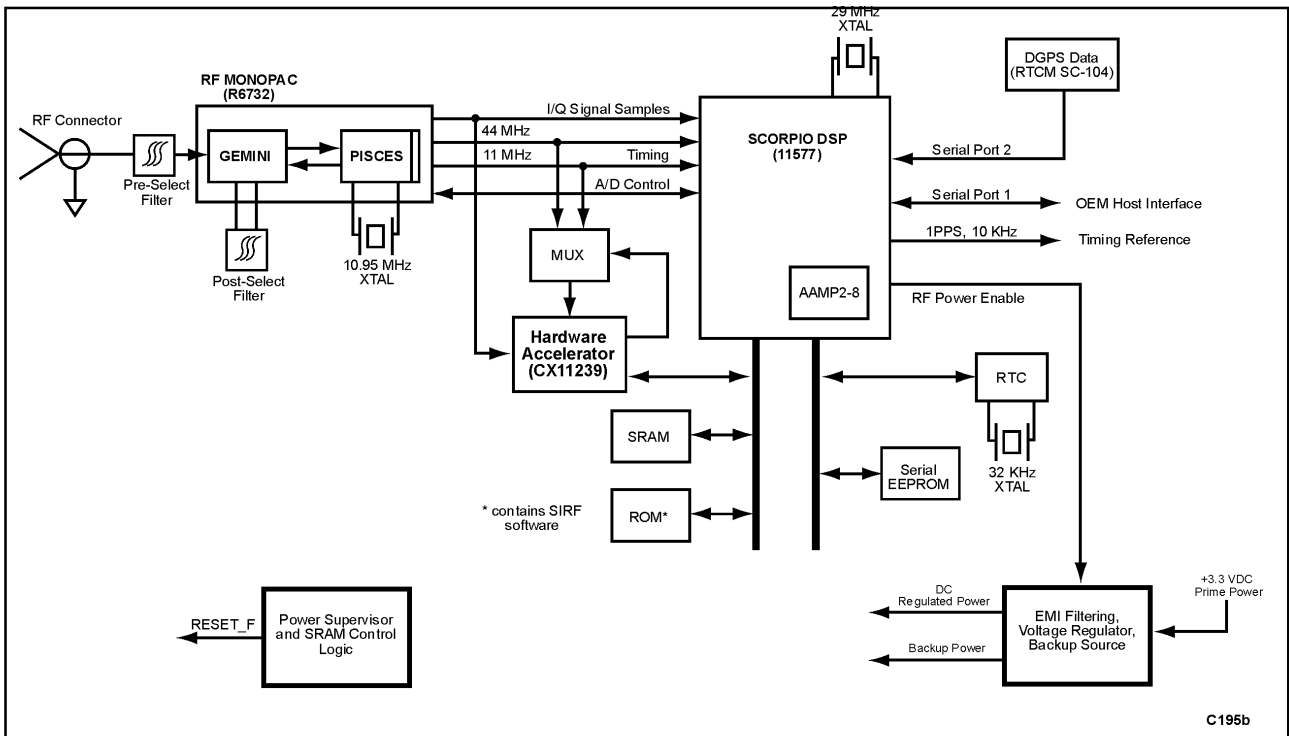

Figure 4. Jupiter Block Diagram With The CX11239

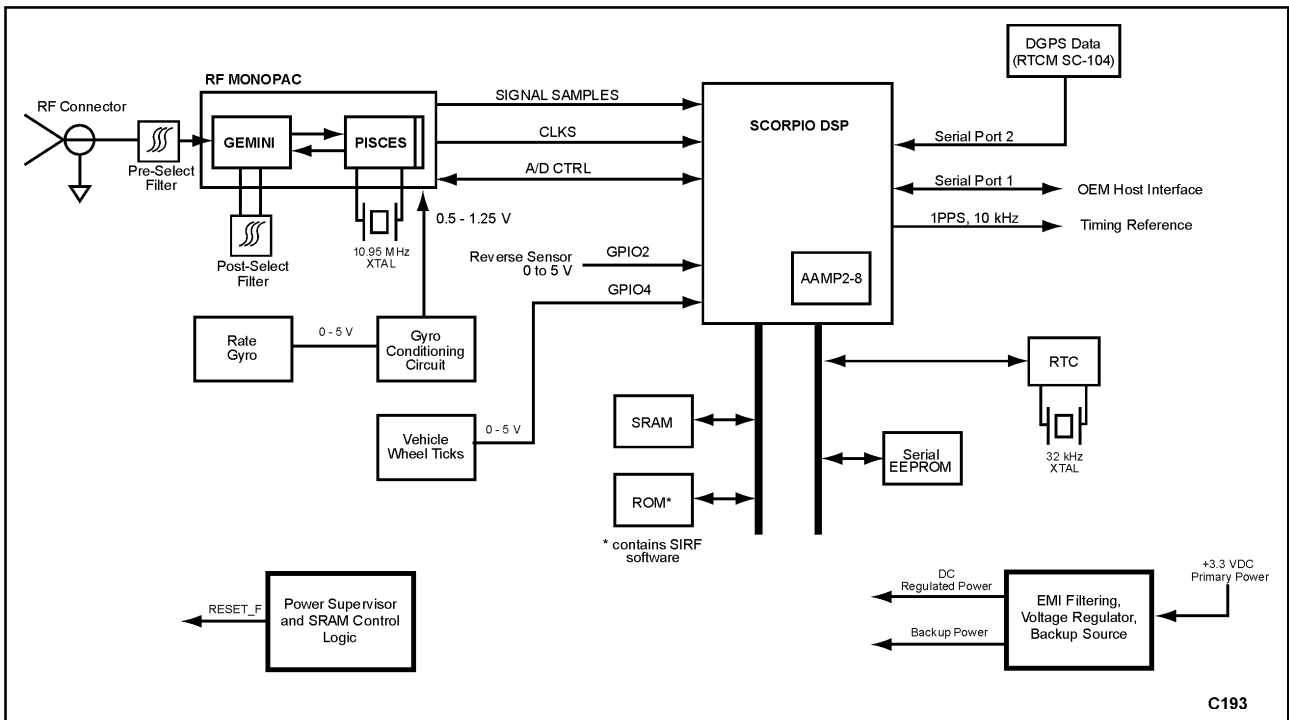

Figure 5. Jupiter Block Diagram With Dead-Reckoning Capability

## Product Applications

The Jupiter receiver is suitable for a wide range of highly integrated, OEM GPS design applications such as:

- Automotive applications
- Marine navigation applications
- Aviation applications
- Handheld applications

Figure 6 illustrates an architecture that might be used to integrate the receiver with an applications processor that drives peripheral devices such as a display and keyboard. The interface between the applications processor and the receiver is through the serial data interface.

## Technical Description

**General Information.** The Jupiter requires +3.3 or +5.0 V primary DC input power depending on the configuration. The receiver can operate from either an active or passive GPS antenna, supplied by the OEM, to receive L-band GPS carrier signals.

Since the receiver determines its position by ranging signals from three or more GPS satellites orbiting the Earth, its antenna must have reasonable visibility of the sky. This is generally not a problem when the receiver is used outdoors in the open. However, when used indoors or inside of an automobile, the antenna should be positioned in such a way as to have an unobstructed “view” of the sky. To establish an initial navigation fix, the receiver requires a

minimum of four satellites in track with good geometry (Geometric Dilution of Precision [GDOP]<10), or three satellites in track and an entered or remembered altitude.

If satellite signals are blocked, the length of time for the receiver to receive those signals and determine its position will be longer. If fewer than three satellites are being tracked, or if the satellite geometry is degraded, signal blockage may result in a failure to navigate.

**Satellite Acquisition.** The Jupiter GPS receiver supports three types of satellite signal acquisition depending on the availability of critical data. Table 2 provides the corresponding TTFF times for each of the following acquisition states.

- **Hot Start.** A hot start occurs when the receiver has been reset during navigation. Most recent position and time are valid in memory. Ephemerides of visible satellites are in SRAM (valid ephemerides are less than four hours old).
- **Warm Start.** A warm start typically results from user-supplied position and time initialization, or from position data stored in memory and time from the Real-Time Clock (RTC) maintained by backup power. Table 1 shows the required accuracy of initialization data.
- **Cold Start.** A cold start acquisition state results when position and/or time is unknown, either of which results in an unreliable satellite visibility list. Almanac information stored in non-volatile memory in the receiver is used to identify previously healthy satellites.

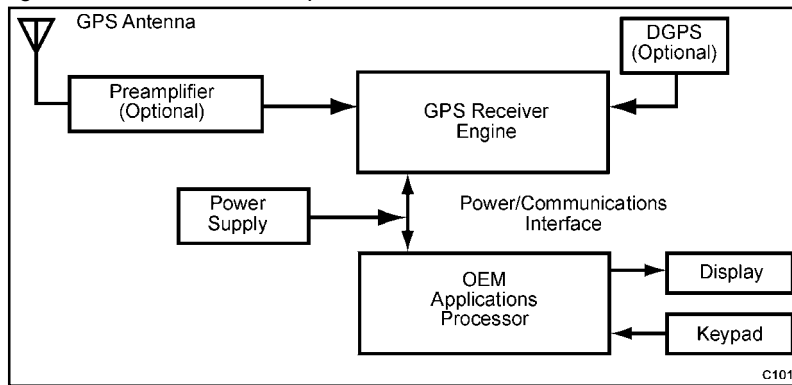

Figure 6. Jupiter Receiver Architecture

Satellite Acquisition State	Time To First Fix (minutes)		Initial Error Uncertainties (Note 1)		
	Typical	90% Probable	Position (km)	Velocity (m/s)	Time (min)
Hot start (Note 2)	0.30	0.40	100	75	5
Warm start (Note 3)	0.8	1.0	100	75	5
Cold start (Note 4)	2.0	2.5	N/A (Note 5)	N/A (Note 5)	N/A (Note 5)

Times are for a receiver operating at 25°C with no satellite signal blockage.

**Note 1:** Required accuracy of data used for initialized start.

**Note 2:** Hot start occurs when the system has been tracking and is reset. Previous position, approximate time, and satellite ephemerides are all valid in memory.

**Note 3:** Warm start occurs when the receiver is sent approximate position and time at startup, or has a previous valid position and backup power has been applied to the RTC. Satellite ephemerides, if in memory, are more than four hours old.

**Note 4:** Cold start occurs when the receiver is lacking approximate position and/or time (i.e., no back-up battery power to RTC).

**Note 5:** Initial error uncertainties do not apply to cold start.

Table 2. Jupiter Receiver Signal Acquisition

**Navigation Modes.** The Jupiter receiver supports two types of navigation mode operations: Three-Dimensional (3-D) and Two-Dimensional (2-D). Each of these modes is described below:

- **Three-Dimensional Navigation (3-D).** The receiver defaults to 3-D navigation whenever at least four GPS satellites are being tracked. In 3-D navigation, the receiver computes latitude, longitude, altitude, and time information from satellite measurements. The accuracies that can be obtained in 3-D navigation are shown in Table 3. The receiver can be commanded to report valid navigation solutions only when in 3-D navigation.
- **Two-Dimensional Navigation (2-D).** When only three GPS satellite signals are available, and when a fixed value of altitude can be used to produce an acceptable navigation solution, the Jupiter receiver enters the 2-D navigation mode from 3-D navigation. The receiver uses a fixed value of altitude determined during prior 3-D navigation or as provided by the OEM.

In 2-D navigation, the navigational accuracy is primarily determined by the relationship of the fixed value of altitude to the true altitude of the antenna. If the fixed value is correct, the horizontal accuracies shown in Table 3 may be approached. Otherwise, the horizontal accuracies degrade as a function of the error in the fixed altitude. In addition, due to the presence of only three satellite signals, time accuracy degrades and the computed position can be expected to show considerable affects of noise, multipath, and partial blockages.

**Fast Satellite Acquisition Using the CX11239**

The Jupiter receiver configuration that includes the CX11239 Hardware Accelerator can acquire satellites, regardless of the acquisition state, very rapidly. The CX11239 is an optimised satellite signal detector that can find the satellite signals up to 100 times faster than the BP. This permits very fast TTFF compared to the BP. Table 4 gives some typical TTFF times using the CX11239.

	Position (meters)				Velocity
	Horizontal		3-D	Vertical	(meters/sec)
	CEP (50%)	2 dRMS (95%)	SEP (50%)	VEP (50%)	3-D (2 sigma)
Full Accuracy C/A	2.8	4.9	5	3.2	0.1
Standard Positioning Service (SPS)	50	100	200	173	Note 1
<i>Note 1: Velocity accuracies for SPS are not specified for the GPS system.</i>					

**Table 3. Jupiter Navigational Accuracies**

Satellite Acquisition State	Time To First Fix (seconds)
	Typical
Hot start	<9
Warm start	<35
Cold start	<45

**Table 4. Signal Acquisition Using the CX11239**

**CX11239 Low-Power Navigation**

The receiver can use the CX11239 in place of the BP’s tracking loops for lowest power navigation. In this type of operation, the CX11239 collects a 20 ms sample from the RF section, then determines satellite ranges from that sample. The RF section operates less than five percent of the time and the BP does not use its tracking loops. This

reduces average power consumption to about one-fourth of normal full-power tracking.

As a result of this type of tracking, the receivers' position solutions tend to be less precise due to the loss of carrier smoothing, and heading and velocity cannot be provided.

## Technical Specifications

### Operational Characteristics

**Signal Acquisition Performance.** Refer to Table 2. The values shown are based on unobstructed satellite signals.

**Accuracy.** Accuracy is a function of the entire Navstar GPS system and geometry of the satellites at the time of measurement. In general, individual receivers have very little influence over the accuracy provided. Navigational accuracies using Full Accuracy C/A Code (SA Off) and the SPS (SA On) are shown in Table 3. These accuracies are based on a Position Dilution of Precision (PDOP) of 6.0 and the maximum vehicle dynamic of 500 m/s.

**Solution Update Rate.** Once per second.

**Reacquisition.** 1 second typical with a 10 second blockage.

**Serial Data Output Protocol.** NAVMAN binary serial I/O messages and NMEA 0183 v2.1 (selected messages).

### Power Requirements

Regulated primary power for the Jupiter GPS receiver is required according to the information provided in Table 5.

Besides regulated primary power, the board can be supplied with backup power to maintain SRAM and RTC states whenever primary power is removed. Backup power must be between 2.5 and 3.5 V (for all boards, regardless of regulated primary power voltage), and will draw between 50 and 70 mA when primary power is removed. When primary power is present, the board will draw no current from the backup source.

When the receiver is operated with an active GPS antenna, the antenna's maximum preamp "pass-through" current is 50 mA at voltages up to +12 V. This current must be limited outside of the receiver.

### Radio Frequency Signal Environment

**RF Input.** 1575.42 MHz (GPS L1 frequency) at a level between -130 dBW and -163 dBW. If an active antenna is used, the best results are obtained when total gain (antenna gain, amplifier gain, and cable loss) is in the range of 12 to 18 dB. Maximum total gain must be less than 23 dB.

**Burnout Protection.** -10 dBW signal within a bandwidth of 10 MHz centered about the L1 carrier frequency.

### Physical

**Dimensions.** 2.800 x 1.600 x 0.440 inches (71 x 41 x 11 mm).

**Weight.** Depending on configuration, not to exceed 0.88184 oz (25 grams).

### Environmental

**Cooling (operating/storage).** Convection.

**Temperature.** -40°F to 185°F (-40°C to +85°C).

**Humidity.** Relative humidity up to 95 percent non-condensing or a wet-bulb temperature of 95°F (+35°C), whichever is less.

**Altitude (operating/storage).** -1000 feet to 60,000 feet (-304.8 m to 18288 m).

**Maximum Vehicle Dynamic.** 500 m/s (acquisition and navigation).

**Vibration.** Full performance. See the composite SAE curve in Figure 7. Survival, 18G peak, 5 ms duration.

**Shock.** Shipping (in container): 10 drops from 2.5" (75 cm) onto a concrete floor.

Version	Input Power	Power Requirement
TU30-D400	Voltage	+3.15 to +3.45 V DC
	Current (typical)	130 mA (75 mA under Power Management)
	Current (maximum)	160 mA
	Ripple	100 mV
TU30-D410	Voltage	+4.75 to 5.25 V DC
	Current (typical)	190 mA
	Current (maximum)	225 mA
	Ripple	150 mV
TU30-D420	Voltage	+3.15 to +3.45 V DC
	Current (typical)	140 mA
	Current (maximum)	190 mA
	Ripple	150 mV
TU30-D430	Voltage	+3.15 to +3.45 V DC
	Current (typical)	130 mA (50 mA under Power Management)
	Current (maximum)	225 mA
	Ripple	150 mV

**Table 5. Jupiter Operational Power Requirements (Typical, Measured at 77°F 25°C)**

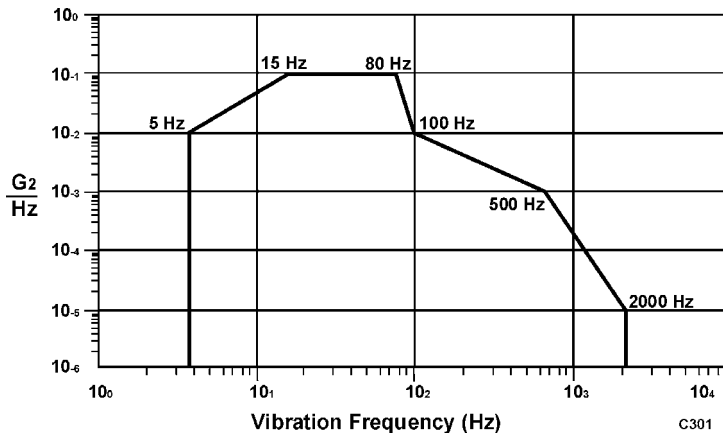

Figure 7. SAE Composite Curve (Random Noise)

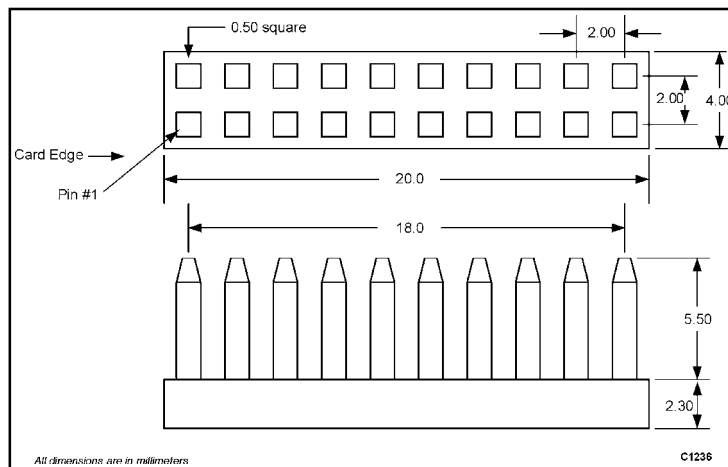

Figure 8. 20-Pin Interface Connector (J1)

## OEM Interface Connector

The OEM communications interface is a dual row, straight 2x10 pin field connector header. The pins are spaced on 2.0 mm (0.0787 in) centers and the pin lengths are 5.5 mm (0.216 in). Figure 8 diagrams the 20-pin I/O connector and shows the pin 1 reference location.

The mating female connector is an IDC receptacle, available from companies such as Berg (part number 89361-120). A 2 mm ribbon cable is available from AMP (part number 1-57051-3).

Refer to the Ordering Information table at the end of this Data Sheet for antenna connector options.

## Mechanical Layout

The mechanical drawing for the Jupiter board is shown in Figure 9.

## ESD Sensitivity

The Jupiter GPS receiver contains Class 1 devices. The following Electrostatic Discharge (ESD) precautions are recommended any time the protective metal shielding is removed:

- Protective outer garments.
- Handle device in ESD safeguarded work area.
- Transport device in ESD shielded containers.
- Monitor and test all ESD protection equipment.

Treat the Jupiter receiver as extremely sensitive to ESD.

## Hardware Interface

The electrical interface of the Jupiter GPS receiver is through a 20-pin miniature connector. The function of each pin is described in Table 6.

**Note** that the input power pins are different between the +3.3 V and +5 V configurations. Pin 2 is dedicated to +5 V boards and pin 4 is dedicated to + 3.3 V boards.

## DC Input Signals

### Pin J1- 1: Antenna Preamp Voltage Input (PREAMP)

This signal is used to supply an external voltage to the GPS antenna pre-amplifier (normally +5 V DC).

### Pins J1-2 and J1-4: Primary +5 V DC Power Input and Primary +3.3 V DC Power Input (PWRIN\_5 and PWRIN\_3)

Jupiter is available in both +3.3 and +5 V configurations.

**Note** that input power for the +3.3 V configurations is on J1-4; the input power is applied to J1-2 for the +5 V configuration. The ground pins provide the return path for both configurations.

**Pin J1-3: Battery Backup Voltage Input (VBATT).** Jupiter boards contain SRAM (read/write memory) and an RTC that can be powered by backup power at low current when primary power is removed. Start-up time is generally improved when power is maintained to the SRAM and RTC since the data required to predict satellite visibility and to compute precise satellite positions is maintained.

VBATT should always be implemented for dead reckoning modes for best performance.

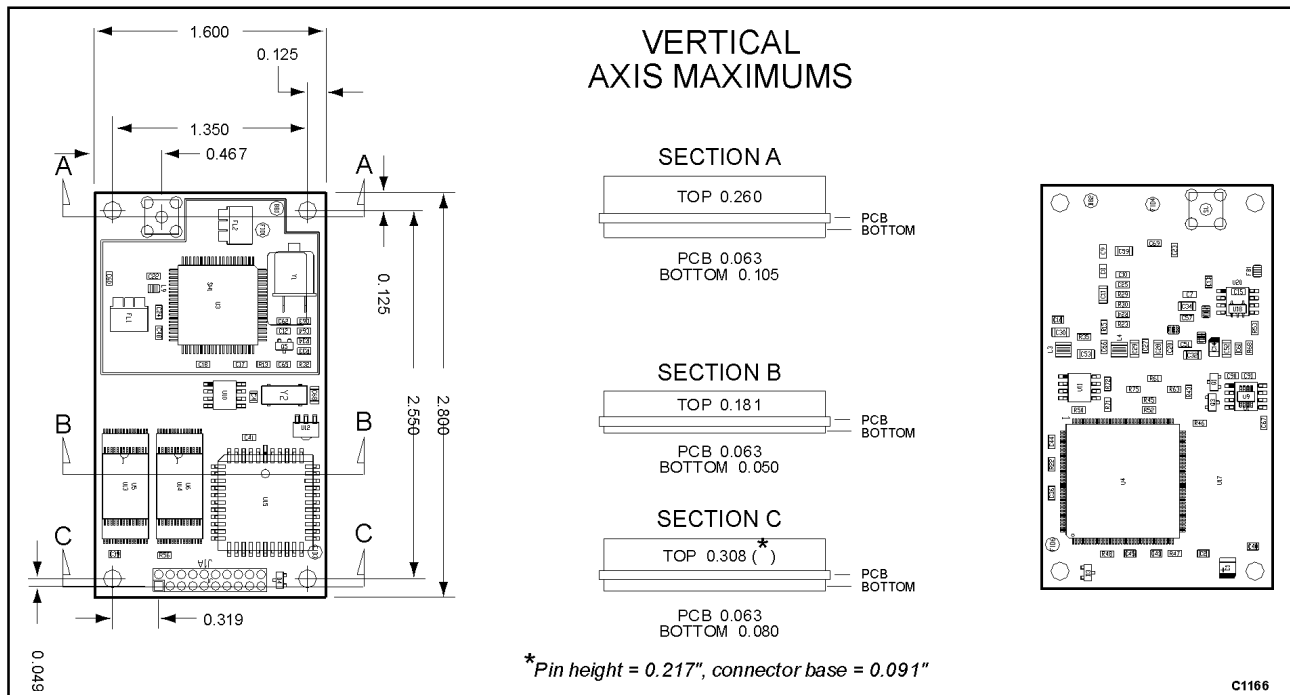

Figure 9. Mechanical Drawing of the Jupiter GPS Receiver Board

Pin #	Name	Description	Pin #	Name	Description
1	PREAMP	Antenna preamp voltage input	11	SDO1	Serial data output port #1
2	PWRIN_5	Primary +5 V DC power input	12	SDI1	Serial data input port #1
3	VBATT	Battery backup voltage input *See Note 2	13	GND	Ground
4	PWRIN_3	Primary +3.3 V DC power input	14	SDO2	Serial data output port #2
5	M_RST	Master reset input (active low)	15	SDI2	Serial data input port #2
6	GYRO	Heading rate gyro input or reserved (no connect) (Note 1)	16	GND	Ground
7	GPIO2	NMEA protocol select/backup sensor (Note 1)	17	GND	Ground
8	GPIO3	EEPROM default select	18	GND	Ground
9	GPIO4	Speed indication or reserved (no connect) (Note 1)	19	TMARK	1PPS time mark output
10	GND	Ground	20	10KHZ	10 kHz clock output

**Note 1:** Pins 6, 7, and 9 have dual functions depending on the specific Jupiter receiver configuration. Refer to the description of these pins in this Data Sheet for further clarification.

**Note 2:** VBATT of 3.3 V works for all models. 5.0 Volts may be used for 5.0 Volt models.

Table 6. Jupiter Receiver J1 Interface Pin Descriptions



Voltage to pin J1-3 must be between 2.5 and 3.5 VDC (regardless of the board's primary power voltage). During times when primary power to the board is off, current is typically 50 to 70 mA, depending on the specific SRAM chips on the board. When the board is powered by primary power, no current is drawn from this pin.

#### Pin J1-5: Master Reset (M\_RST) - Active Low

This signal is the master reset, used to warm start the receiver. This pin should be tied to a logic "high" with a 47 k $\Omega$  resistor.

**Note:** For the receiver to operate normally, the M\_RST signal must be pulled to a CMOS logic "high" level coincident with, or after, the application of prime DC power to the receiver. The M\_RST signal must be held at ground level for a minimum of 150 ns to assure proper generation of a hardware reset.

#### Pin J1-6: Heading Rate Gyro Input (GYRO)

This pin is used for the heading rate gyro input on Jupiter TU30-D420 receivers (for other receivers in the TU30-D400 series, this pin is not used).

Characteristics of the input signal are:

- 0 to 5 V range
- 2.5 V output when gyro is not being rotated
- Clockwise rotation of the gyro causes voltage to rise
- Maximum voltage deviation due to rotation should occur with a turning rate of 90 degrees/second or less

The gyro should be mounted so its sensitive axis is as nearly vertical as practical. Deviations from the vertical reduce sensitivity for heading changes in the horizontal direction. Acceptable performance can be achieved with mounting deviations of several degrees, but better performance is achieved when the gyro is mounted closer to vertical. Contact NAVMAN for suggested sources for rate gyros.

#### Pin J1-7: NMEA Protocol Select/Reverse (GPIO2)

This pin is used to receive an optional backup (Reverse gear) signal from the vehicle on Jupiter TU30-D420 receivers. A "low" on this input indicates the vehicle is in reverse gear.

Use of this signal is optional; if it is not used, the effect of occasional backing by the vehicle does not significantly degrade navigation performance.

To ensure minimum current when backup voltage is used, be sure this input is not pulled up external to the board.

For other receivers in the TU30-D400 series, this pin is connected to GPIO2, which is used to allow forced selection of the NMEA messaging protocol. With these receivers, when this pin is held "low" at restart or power-up, the receiver is forced into NMEA protocol at 4800 baud (no parity, 8 data bits, 1 stop bit) on serial I/O port 1. If the pin is held "high" at restart or power-up, the receiver uses the last message protocol and port baud rate that was used before the restart or power-off.

#### Pin J1-8: EEPROM Default Select (GPIO3)

This signal is used to enable or disable the internal EEPROM. When this pin is grounded, the receiver uses factory defaults rather than any settings or tracking history stored in EEPROM.

**Caution:** Pin J1-8 should only be grounded to recover from unusual situations. When this is done, the receiver takes longer to find and track satellites, and all user settings are lost, including I/O port settings (baud rate, message protocol, etc.) and navigation settings.

#### Pin J1-9: Speed Indication (GPIO4)

This pin is used to receive speed pulses (wheel ticks) from the vehicle on Jupiter TU30-D420 receivers. For other receivers in the TU30-D400 series, this pin is connected to GPIO4, which is used for factory test purposes (in these cases, no connection should be made to pin J1-9).

For dead reckoning receivers, the input to this pin is a pulse train generated in the vehicle. The pulse frequency is proportional to the vehicle velocity. In most vehicles, the Automatic Braking System (ABS), transmission, or drive shaft generate these pulses, or wheel ticks. System design must restrict the pulses between 0 and 5 V with a duty cycle near 50 percent.

Maximum frequency for the wheel ticks at top vehicle speed is approximately 800 Hz. If a vehicle generates wheel ticks that could exceed 800 Hz at the top expected vehicle speed, a flip-flop or digital counter should divide the wheel tick signal so that the top frequency is below 800 Hz.

The receiver periodically senses the state of pin J1-9 using a timed process. Wheel ticks must be within some broad range of frequencies for the receiver to use them. Detection limits for speed pulses are the following:

- Minimum detectable rate: 1 pulse/second (pps)
- Maximum detectable rate: 800 pps

To illustrate how this relates to speed, assume two vehicles, one that generates 1000 ticks/km and the other 9000 ticks/km. The minimum and maximum speeds the system can detect are computed as follows:

##### Vehicle 1: 1000 ticks/km

Minimum detectable speed:

$$\frac{1 \text{ tick/sec}}{1000 \text{ ticks/km}} \times \frac{3600 \text{ sec}}{\text{hr}} = 3.6 \text{ km/hr (2.2 mi/hr)}$$

Maximum detectable speed:

$$\frac{800 \text{ ticks/sec}}{1000 \text{ ticks/km}} \times \frac{3600 \text{ sec}}{\text{hr}} = 2880 \text{ km/hr (1790 mi/hr)}$$

##### Vehicle 2: 9000 ticks/km:

Minimum detectable speed:

$$\frac{1 \text{ tick/sec}}{9000 \text{ ticks/km}} \times \frac{3600 \text{ sec}}{\text{hr}} = 0.4 \text{ km/hr (0.25 mi/hr)}$$

Maximum detectable speed:

$$\frac{800 \text{ ticks/sec}}{9000 \text{ ticks/km}} \times \frac{3600 \text{ sec}}{\text{hr}} = 320 \text{ km/hr (199 mi/hr)}$$

These examples illustrate the minimum number of wheel ticks per kilometer that gives reasonable performance and the maximum per kilometer given a broad operating range. A higher number of ticks/km may be used if a lower maximum vehicle speed is acceptable or if a hardware divider circuit is used. For a divide-by-two circuit, 18000 ticks/km allows the same top speed and low speed resolution as 9000 ticks/km without the divider. To ensure minimum current when backup power is used, this input must be pulled to a CMOS low external to the board.

Information on locating the speed pulse wiring in many current vehicles may be obtained from a document titled **Vehicle Speed Sensor Locations For Many Vehicles**, available from SCS, 1200 W. Risinger Road, Fort Worth, TX 76134 Website: [www.scsfrigitte.com](http://www.scsfrigitte.com)

### Serial Communication Signals

**Note:** The serial communication signals described below must be applied according to the limits shown in Table 7.

### Pins J1-11, 12, 14, and 15: Serial Data Ports SDO1, SDI1, SDO2, and SDI2

Serial port 1 (SD01 and SDI1), also called the Host Port, is the primary communications port for the receiver. Commands to the receiver are entered through SDI1 and data from the receiver is transmitted through SDO1. Both binary and NMEA messages are transmitted and received across the Host Port's serial I/O interface. All of the output and input binary messages for the Jupiter receiver are listed in Table 8, along with their corresponding message IDs. All of the output and input NMEA messages are listed in Table 9, along with their corresponding message IDs.

Serial port 2 (SD02 and SDI2), also called the Auxiliary Port, is reserved for Differential GPS (DGPS) corrections sent to the receiver. Serial port 2 input (SDI2) receives DGPS messages at 9600 baud (no parity, 8 data bits, 1 stop bit). These messages are in Radio Technical Commission for Maritime services (RTCM) SC-104 format. Table 10 lists the specific RTCM SC-104 messages implemented in the Jupiter receivers.

Symbol	Parameter	Limits	Units
PWRIN	Main Power Input to the Jupiter	+3.15 to +3.45 (Note 1)	V
VIH (min)	Minimum High-Level Input Voltage	0.7 x PWRIN	V
VIH (max)	Maximum High-Level Input Voltage	PWRIN	V
VIL (min)	Minimum Low-Level Input Voltage	-0.3	V
VIL (max)	Maximum Low-Level Input Voltage	0.3 x PWRIN	V
VOH (min)	Minimum High-Level Output Voltage	0.8 x PWRIN	V
VOH (max)	Maximum High-Level Output Voltage	PWRIN	V
VOL (min)	Minimum Low-Level Output Voltage	0	V
VOL (max)	Maximum Low-Level Output Voltage	0.2 x PWRIN	V
tr, tf	Input Rise and Fall Time	50	ns
C out	Maximum Output Load Capacitance	25	pF
<b>Note 1:</b> +4.75 to +5.25 V for TU30-D410 receivers.			

**Table 7. Jupiter Digital Signal Requirements**

Output Message Name	Message ID	Input Message Name	Message ID
Geodetic Position Status Output (*)	1000	Geodetic Position and Velocity Initialization	1200
Channel Summary (*)	1002	User-Defined Datum Definition	1210
Visible Satellites (*)	1003	Map Datum Select	1211
Differential GPS Status	1005	Satellite Elevation Mask Control	1212
Channel Measurement	1007	Satellite Candidate Select	1213
ECEF Position Output	1009	Differential GPS Control	1214
Receiver ID (**)	1011	Cold Start Control	1216
User-Settings Output	1012	Solution Validity Criteria	1217
Raw Almanac	1040	User-Entered Altitude Input	1219
Raw Ephemeris	1041	Application Platform Control	1220
Raw Iono/UTC Corrections	1042	Nav Configuration	1221
Built-In Test Results	1100	Raw Almanac	1240
Global Output Control Parameters	1101	Raw Ephemeris	1241
Measurement Time Mark	1102	Raw Iono/UTC Corrections	1242
UTC Time Mark Pulse Output (*)	1108	Perform Built-In Test Command	1300
Frequency Standard Parameters In Use	1110	Restart Command	1303
Serial Port Communication Parameters In Use	1130	Frequency Standard Input Parameters	1310
EEPROM Update	1135	Serial Port Communication Parameters	1330
EEPROM Status	1136	Message Protocol Control	1331
Frequency Standard Table Output Data	1160	Factory Calibration Input	1350
Error/Status	1190	Raw DGPS RTCM SC-104 Data	1351
		Frequency Standard Table Input Data	1360
(*) Enabled by default at power-up.			
(**) Once at power-up/reset.			

**Table 8. Jupiter Receiver Binary Data Messages**

Output Message Name	Message ID	Input Message Name	Message ID
NAVMAN Proprietary Built-In Test (BIT) Results	BIT	NAVMAN Proprietary Built-In Test (BIT) Command	IBIT
NAVMAN Proprietary Error/Status	ERR	NAVMAN Proprietary Log Control Message	ILOG
GPS Fix Data (*)	GGA	NAVMAN Proprietary Receiver Initialization	INIT
GPS DOP and Active Satellites (*)	GSA	NAVMAN Proprietary Protocol Message	IPRO
GPS Satellites in View (*)	GSV	Standard Query Message	Q
NAVMAN Proprietary Receiver ID (**)	RID		
Recommended Minimum Specific GPS Data (*)	RMC		
Track Made Good and Ground Speed	VTG		
NAVMAN Proprietary Zodiac Channel Status (*)	ZCH		
(*) Enabled by default at power-up.			
(**) Output by default once at power-up or reset.			

**Table 9. Jupiter Receiver NMEA v2.01 Data Messages**

Message ID	Title	Used For DGPS Corrections?
1	Differential GPS Corrections	Yes
2	Delta Differential GPS Corrections	Yes
3	Reference Station Parameters	No
9	Partial Satellite Set Differential Corrections	Yes

**Table 10. Jupiter Receiver Supported RTCM SC-104 Data Messages**

**Pin J1-19: 1PPS Time Mark Pulse (TMARK)**

Jupiter receivers generate a 1PPS signal that is aligned with the UTC second. The signal is a positive-going pulse of approximately 25.6 ms duration. When the receiver has properly aligned the signal, the rising edge is within 50 ns (1 sigma) of the UTC second. This signal is derived from the 10 kHz clock output (pin J1-20), which is valid under the same conditions as the 1PPS Time Mark pulse.

**Pin J1-20: 10 kHz clock Output (10KHZ)**

This signal is a 10 kHz square wave that is precisely aligned with the UTC second. The 1PPS Time Mark pulse is derived

from this signal. The receiver aligns the 10 kHz clock output so that one rising edge is aligned within 50 ns (1 sigma) of UTC. Then, the receiver indicates which rising edge is aligned by causing the 1PPS Time Mark pulse to rise at the same time.

**Pins J1-10, 13, 16, 17, and 18: Ground (GND)**

DC grounds for the board. All grounds are tied together through the receiver's printed wiring board (PWB) ground plane and should all be grounded externally to the receiver.

## Ordering Information

Model Name	Manufacturing Part Number (*)	Antenna Options
Jupiter 3.3 V, low power	TU30-D400	-021, right angle OSX -031, straight OSX
Jupiter 5.0 V, standard receiver	TU30-D410	-021, right angle OSX -031, straight OSX -041, right angle SMB
Jupiter 3.3 V, with dead reckoning	TU30-D420	-031, right angle OSX
Jupiter 3.3 V, with CX11239 device	TU30-D430	-021, right angle OSX
Jupiter 5.0 V, with dead reckoning	TU30-D440	-021, right angle OSX
(*) Contact NAVMAN for the latest revision part number and optional GPS antenna connector.		

Information in this document is provided in connection with Navman, Inc. ("NAVMAN") products. These materials are provided by NAVMAN as a service to its customers and may be used for informational purposes only. NAVMAN assumes no responsibility for errors or omissions in these materials. NAVMAN may make changes to specifications and product descriptions at any time, without notice. NAVMAN makes no commitment to update the information and shall have no responsibility whatsoever for conflicts or incompatibilities arising from future changes to its specifications and product descriptions.

No license, express or implied, by estoppel or otherwise, to any intellectual property rights is granted by this document. Except as provided in NAVMAN's Terms and Conditions of Sale for such products, NAVMAN assumes no liability whatsoever.

THESE MATERIALS ARE PROVIDED "AS IS" WITHOUT WARRANTY OF ANY KIND, EITHER EXPRESSED OR IMPLIED, RELATING TO SALE AND/OR USE OF NAVMAN PRODUCTS INCLUDING LIABILITY OR WARRANTIES RELATING TO FITNESS FOR A PARTICULAR PURPOSE, CONSEQUENTIAL OR INCIDENTAL DAMAGES, MERCHANTABILITY, OR INFRINGEMENT OF ANY PATENT, COPYRIGHT OR OTHER INTELLECTUAL PROPERTY RIGHT. NAVMAN FURTHER DOES NOT WARRANT THE ACCURACY OR COMPLETENESS OF THE INFORMATION, TEXT, GRAPHICS OR OTHER ITEMS CONTAINED WITHIN THESE MATERIALS. NAVMAN SHALL NOT BE LIABLE FOR ANY SPECIAL, INDIRECT, INCIDENTAL, OR CONSEQUENTIAL DAMAGES, INCLUDING WITHOUT LIMITATION, LOST REVENUES OR LOST PROFITS, WHICH MAY RESULT FROM THE USE OF THESE MATERIALS.

NAVMAN products are not intended for use in medical, lifesaving or life sustaining applications. NAVMAN customers using or selling NAVMAN products for use in such applications do so at their own risk and agree to fully indemnify NAVMAN for any damages resulting from such improper use or sale.

Copyright © 2002, Navman, Inc. All Rights Reserved. NAVMAN is a registered trademark of Navman NZ Limited.